

## SP120H Handheld Thermal Camera



The HIKMICRO SP120H high-performance handheld thermal camera is an excellent choice for industrial, predictive, oil and gas, and utility maintenance inspections. It features a high-sensitivity HIKMICRO VOx detector (NETD < 20 mK) with a resolution of 1280 x 1024 and can measure temperatures up to 2200°C. This flexible and ergonomic thermal imager includes an electronic viewfinder and a 180° rotating lens, simplifying long outdoor inspections. Advanced features such as GPS and compass annotations, continuous digital zoom, and 1-Tap level and span make it easy for professionals to survey equipment and detect malfunctions. With the HIKMICRO Viewer App or HIKMICRO Analyzer software, users can transfer, analyze, and share images, as well as generate reports for free.

### ▪ Key Features

- Thermal resolution: 1280 x 1024 (1 310 720 pixels), NETD : < 20 mK (@ 25 °C, F#=1.0)
- Temperature measurement range : -40°C to 2200°C (-40°F to 3992°F)
- Accuracy: Max. ( $\pm 2^{\circ}\text{C}/3.6^{\circ}\text{F}$ ,  $\pm 2\%$ )
- The 90° rotating screen and the 180° rotating lens design
- 1024 x 768 OLED electronic viewfinder and auto-brightness 5.1-inch color LCD display
- 1.x to 12.x continuous digital zoom
- Manual, automatic, and 1-Tap Level and Span
- GPS & compass annotation functions
- 30 Hz image frequency
- Up to 4 hours continuous running

## ▪ Specification

Infrared Image	
IR Resolution	1280 × 1024 (1,310,720 pixels)
SuperIR	2560 × 2048 (5,242,880 pixels)
NETD	< 20 mK (@ 25 °C, F#=1.0)
Image Frequency	30 Hz
Detector Pitch	12 μm
Spectral Range	7.5 to 14 μm
Focal Length	L8: 112.2 mm L12: 72.9 mm L25: 35 mm L50: 17.6 mm
F-number	L8: F1.3 L12: F1.2 L25: F1.1 L50: F1.1
Field of View (FOV)	L8: 7.9° × 6.3° L12: 12° × 9.6° L25: 25° × 20° L50: 50° × 40°
Spatial Resolution (IFOV)	L8: 0.11 mrad L12: 0.17 mrad L25: 0.34 mrad L50: 0.68 mrad
Min. Focus Distance	L8: 5m (16.4 ft) L12: 1.65m (5.41 ft) L25: 0.3m (0.98 ft) L50: 0.2m (0.66 ft)
Focus Mode	Laser Assisted AF/Continuous AF/AF/Manual Focus/Touch AF
Focus Speed	Approx. 2 second
Image Display	
Visual Camera	4208 × 3120 (13 MP)
Display	1920 × 1080 Resolution, 5.1" OLED Touch Screen, Lv 360 Cd/m <sup>2</sup>
Screen Brightness	Manual/Auto
Viewfinder	1024 × 768 pixels OLED
Digital Zoom	1.x to 12.x continuous
Color Palettes	White Hot, Black Hot, Rainbow, Ironbow, Red Hot, Fusion, Rain, Blue Red
Focus Mode Palette	Above/Below/Interval
Color Alarm	Above/Below/Interval/Insulation/Condensation
Image Modes	Thermal/Visual/Fusion/PIP/Blending
Measurement and Analysis	
Object Temperature Range	-40°C to 2200°C (-40°F to 3992°F)

Accuracy	Max. ( $\pm 2^{\circ}\text{C}/3.6^{\circ}\text{F}$ , $\pm 2\%$ )
Measurement Tools	Center Spot, Hot Spot, Cold Spot User-definable: Delta T, 10 spots, 1 line, 5 rectangles, and 5 circles
Level and Span Mode	Auto/Manual/1-Tap Touch-Screen
Inspection Route	Yes
<b>Data Storage and Communication</b>	
Storage Media	Removable 128 GB SD Card
Image Storage Capacity	Approx. 30,000 Images
Annotations	Voice note: max. 60 seconds; Text note: max. 200 characters
Video Storage Capacity	Approx. 130 Hours (MP4 video)
Video File Format	MP4 video and radiometric video
Image Format	Radiometric JPEG
IR Live Streaming	Radiometric streaming via USB Non-radiometric streaming via USB and Wi-Fi
<b>General</b>	
Wi-Fi	802.11 b/g/n (2.4 GHz and 5 GHz)
Bluetooth	Bluetooth 4.2
USB Interface	USB Type-C
HDMI Interface	HDMI-D
LED Light	Yes
Laser Pointer	Yes
Laser Distance Meter	Indoor distance: 50 m (164 ft); Outdoor distance: 15 m (49 ft).
Laser	Yes, Class II, Wavelength: 635 nm; Power: < 1 mW
Battery Type	Interchangeable and rechargeable Li-ion battery
GPS & Compass	Yes
Battery Operating Time	Approx. 4 hours
Battery Charging Time	Approx. 2.5 hours fully charged
Power Saving Mode	Yes
Programmable Buttons	2
Protection Level	IP54, IEC 60529
Drop Test Height	1 m (3.28 ft), IEC 60068-2-31
Safety	IEC 61010-1
EMC	EN 301 489-1, EN 301 489-17, EN IEC 61000-6-2, EN IEC 61000-6-3, EN 61326-1
Vibration	2 g, IEC 60068-2-6
Shock	25 g, IEC 60068-2-27
Working Temperature Range	-20°C to 50°C (-4°F to 122 °F)
Storage Temperature Range	-20°C to 60°C (-4°F to 140°F)
Relative Humidity	< 95% non-condensing
Weight	Approx. 1550 g (3.42 lb) (Without lens)

Dimension	220.5 × 151.9 × 88.1 mm (8.68 × 5.98 × 3.47 in) (Without lens)
Tripod Mounting	UNC ¼"-20
Warranty	3 years for the full product, 10 years for the detector, and 2 years for the battery.

### ▪ Available Model

HM-TP9CH-W/W-SP120H-L25

### ▪ Dimension

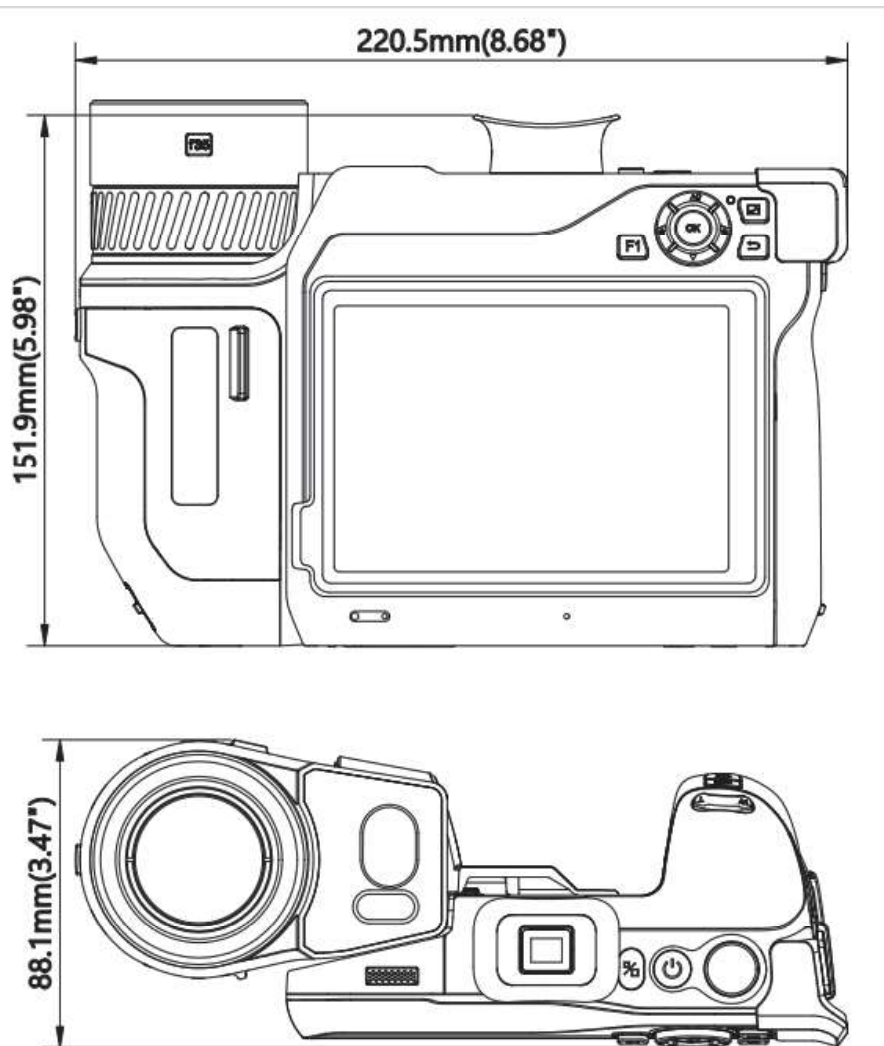

## ▪ Packaging

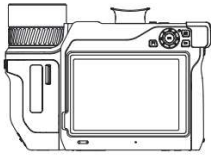

Camera(x1)

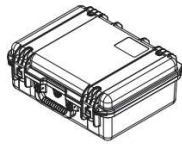

Hard Carrying Case(x1)



QSG(x1)



Lens Caps(x1)

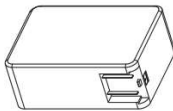

Adapter(x1)

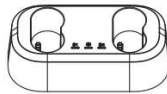

Charging Base(x1)



USB Cable(x2)



Wrist Strap(x1)



Adapter Plug(x4)



Battery(x2)



HDMI Cable(x1)



Neck Strap(x1)

## ▪ Accessory

### ▪ Optional

HM-20322ZC  
SP Series Battery  
Charger



HM-7250DC  
SP Series Battery



HM-SP01-POUCH  
M/G/SP Series Pouch



**COMPLIANCE NOTICE:** The thermal series products might be subject to export controls in various countries or regions, including without limitation, the United States, European Union, United Kingdom and/or other member countries of the Wassenaar Arrangement. Please consult your professional legal or compliance expert or local government authorities for any necessary export license requirements if you intend to transfer, export, re-export the thermal series products between different countries.



**Studánková 395, 149 00 Praha 4 - Újezd**  
**tel.: +420 272 942 720, fax: +420 272 942 722**  
**email: [info@tmvss.cz](mailto:info@tmvss.cz), [www.tmvss.cz](http://www.tmvss.cz)**